

3D-Ansicht /
isometrical view
2:1

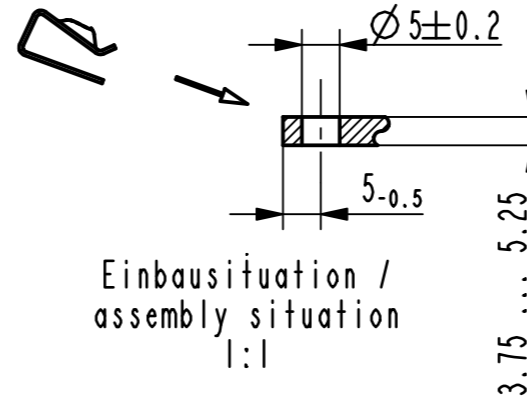

Einbausituation /
assembly situation
1:1

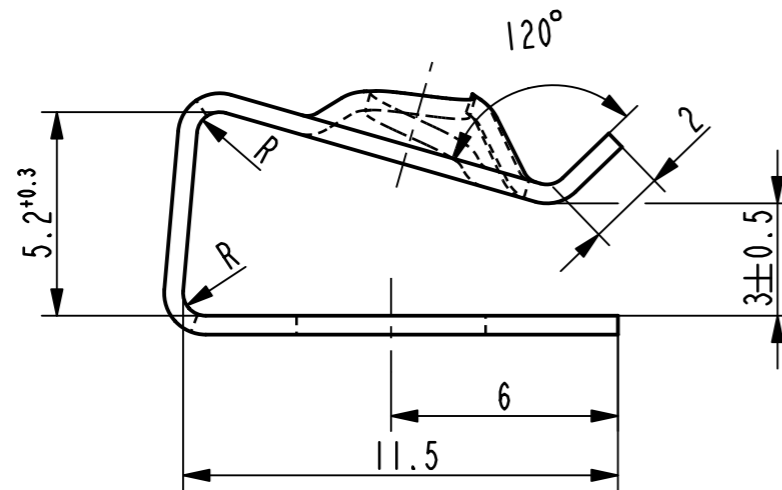
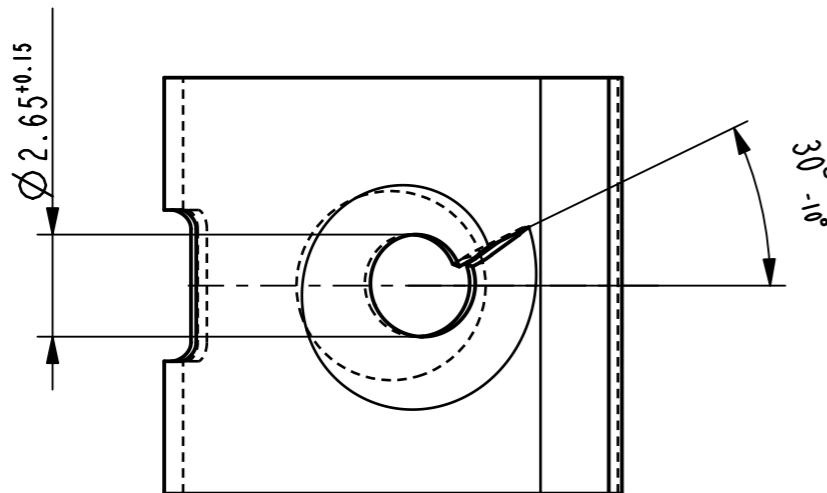

Vor Auslegung einer automatisierten Verarbeitung des Teils sollte Ruecksprache mit Fa. A.Raymond gehalten werden.
Fully automatic processing of the part requires prior consultation with A.Raymond GmbH.

-	-	-	-	-
-	-	-	-	-
-	-	-	-	-
-	-	-	-	-
-	-	-	-	-
-	-	-	-	-
-	-	-	-	-
-	-	-	-	-
-	-	-	-	-
-	-	-	-	-
-	-	-	-	-

Ab	-	Oberflaechenvariante entfernen (3000)	08.10.10	mj
Rev.	Anzahl/ quantity	Aenderungsbeschreibung / modification description	Datum/date	Name

A.Raymond
 GmbH & Co. KG
 Teichstrasse 57
 Germany - 79511 Loerrach
 Phone +49 (0) 7621 174-0
 Fax +49 (0) 7621 174-225

Bei Verstaendnisproblemen beantragen Sie bitte beim Absender die deutsche Fassung vor jeder Anwendung.
"CONDITIONS OF USE"
This drawing and all information (the "Drawing") disclosed are the exclusive property of A.Raymond. By using this Drawing the Addressee acknowledges and accepts that this Drawing (1) is covered by A.Raymond' intellectual property rights or know-how and (2) is provided under the following conditions who represent a Deposit Agreement. This Drawing is for Addressee' Internal use only limited to its estimation. Without prior written consent of A.Raymond, no permission or rights for any purpose, is hereby granted, such as, without any limitation, (1) the copy, in part or entirely, (2) and/or the presentation, in part or entirely, to any other third party outside the Addressee' company or in the company but with no interest (3) and/or the distribution of the Drawing, in part or entirely, in any medium (4) and/or the creation of any derivative work. In case of breach of these conditions, Addressee shall indemnify A.Raymond from and against all damages (compensatory or consequential), costs, expenses and charges, caused or arising out of or attributable to its willful misconduct, fraud, negligence, infringement of A.Raymond' intellectual property rights. If the Addressee does not accept these conditions, please notify A.Raymond' sender immediately.

Schutzrechte/ patent rights	vorbehalten / all rights reserved		Rasch Code/ classification	AAAAB
Ersatz fuer/ substitut for	013695_c_01/Aa/01.06.2006	Entw.Ref./ dev.ref.	Projekt-Nr./ project no.	

Masstab/ scale	Format	Allgemeintoleranz/ general tolerance	Datum/ date	08.10.2010
5:1	A3	±0.3 / ±5°	Erstellt von/ prepared by	M. Junge

Projektion / projection	ALL DIMENSIONS ARE IN MILLIMETERS	Freigegeben/ approved	20101008120548	
	Blechdicke/ mat. thickness DIN EN 10140	0.50	Volumen/ volume (mm³)	138.4
			Gewicht/ weight (g)	1.1

Oberfl./ finish	verzinkt / passiviert farblos zinc plated / passivated colourless	Oberfl. Code/ finish code	3250
--------------------	--	------------------------------	------

Werkstoffbehandl./ material treatment	zwischenstufenverguetet / austempered 375 ... 475 HV 5
--	---

Werkstoff/ material	C67S DIN EN 10132-4	Mat. code	1000
------------------------	---------------------	-----------	------

Benennung/
title
Blechmutter
 fuer Gewinde EN ISO 1478-ST3.5
sheet metal nut
 for thread EN ISO 1478-ST3.5

Teil-Nr./ part no.	013695-0-02	Drawing type	Customer
-----------------------	-------------	--------------	----------

Kundenteile-Nr. / customer part no.	-	Blatt / sheet	1 / 1
CAD system & version	ProE WF3	Dateiname / filename	013695-0C00

-	-	-
Teil-Nr. / part no.	Oberflaeche / Farbe / finish / colour	Oberfl. Code/ finish code
Ausfuehrung / Execution		