

VUE ISO/3D VIEW
 ECHELLE/SCALE : 1:1

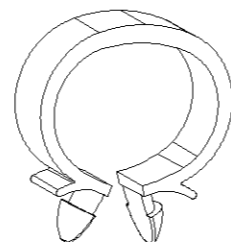

Exemple d'utilisation/Use example
 Echelle/Scale : 1:1

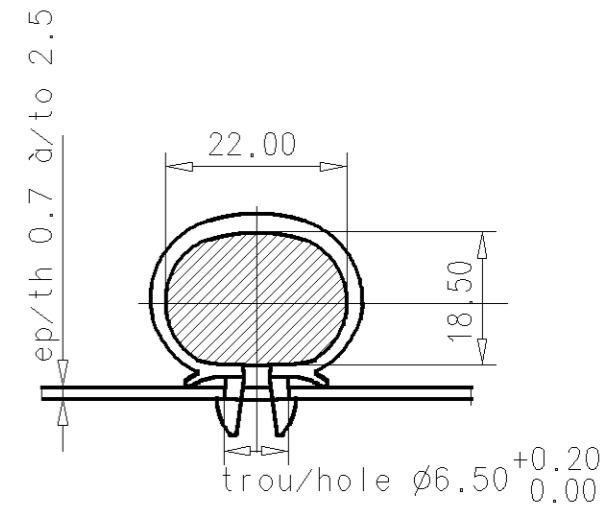

VERIFIER L ECHELLE APRES PHOTOCOPIE / BEWARE SCALE AFTER COPY

Jb	--	INTERNATIONAL DRAWING	09/02/09	FA
Ja	--	Mise à jour de la variante 002	28/03/06	SP
J	00	Mise à jour sous informatique	25/06/92	PP
IND	Nb DIM	DESCRIPTIONS / DESIGNATIONS	DATE	VISAS

If the addressee does not accept these conditions, please notify A.Raymond sender immediately.
Si problème de compréhension, merci de demander la version française à A.Raymond avant toute utilisation.
 This drawing and all information (the "Drawing") disclosed are the exclusive property of A.Raymond.
 By using this Drawing the Addressee acknowledges and accepts that this Drawing
 (1) is covered by A.Raymond intellectual property rights or know-how, and,
 (2) is provided under the following conditions who represent a Deposit Agreement.
 This Drawing is for Addressee' internal use only limited to its estimation.
 Without prior written consent of A.Raymond, no permission or rights for any purpose, is hereby granted, such as, without any limitation,
 (1) the copy, in part or entirely,
 (2) and/or the presentation, in part or entirely, to any other third party outside the Addressee' company or in the company but with no interest
 (3) and/or the distribution of the Drawing, in part or entirely, in any medium
 (4) and/or the creation of any derivative work.
 In case of breach of these conditions, Addressee shall indemnify A.Raymond from and against all damages (compensatory or consequential), costs, expenses and charges, caused or arising out of or attributable to its willful misconduct, fraud, negligence, infringement of A.Raymond' Intellectual Property rights.

FORMAT	SCALE/ECH	TH/EP(mm)	VOL(mm ³)	WEIGHT/POIDS(g)	SHEET/PLANCHE	TOLERANCE dimension / angle	DATE
A3	4:1				1/1	± 0.50 5°	30/05/73

SURFACE TREATMENT OR COLOR / TRAITEMENT DE SURFACE OU COULEUR:
Noir

MATERIAL TREATMENT / TRAITEMENT STRUCTURAL :
 ACHIEVED/REALISE: **BELMONT**

REPRISE D'HUMIDITE 2* MINI
 VISA:

MATERIAL / MATIERE:
PA 6602 Noir (Type Ultramid A 3 W Noir) Densite 1,13
 APPROVED/APPROUVE: /
 VISA:

TITLE / LIBELLE:
**AGRAFE DE GAINÉ
 SHEATH CLIP**
 PATENTS / BREVETS:

CUSTOMER DATA / REF. CLIENT:
 NUMBER / NUMERO:
053479 .001

