

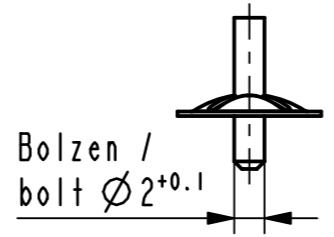

2:1

Einbausituation /
assembly situation

2:1



Bolzen /
bolt Ø 2+0.1

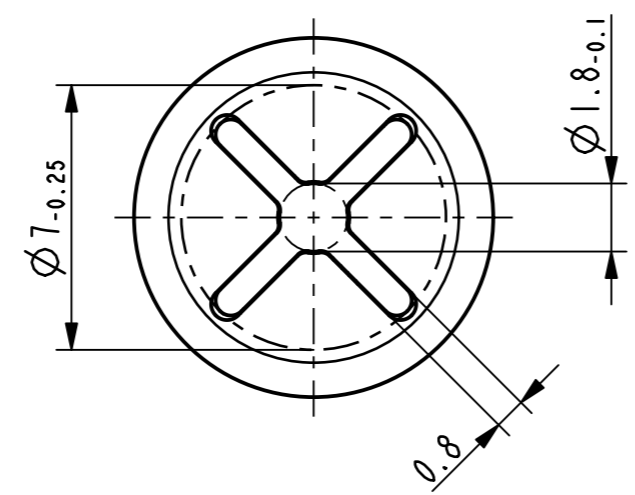
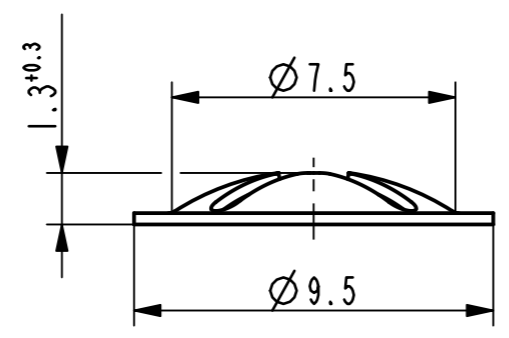

Ab	011876-0-05	verzinkt / passiviert schwarz zinc plated / passivated black	3350
	011876-0-04	verzinkt / passiviert farblos zinc plated / passivated colourless	3250
Teil-Nr. / part no.	Oberflaeche / Farbe / finish / colour		Oberfl. Code/ finish code
Ausfuehrung / Execution			

Vor Auslegung einer automatisierten Verarbeitung des Teils sollte Ruecksprache mit Fa. A.Raymond gehalten werden.
 Fully automatic processing of the part requires prior consultation with A.Raymond GmbH.

-	-	-	-	-
-	-	-	-	-
-	-	-	-	-
-	-	-	-	-
-	-	-	-	-
-	-	-	-	-
-	-	-	-	-
-	-	-	-	-
-	-	-	-	-
-	-	-	-	-

Ab	2x	Oberflaechenvariante 001 (3100) und 002 (3150) entfernt,	04.08.10	Ru
-	-	Oberflaechenvariante 005 (3350) hinzugefuegt	-	-

Rev. Anzahl/quantity Aenderungsbeschreibung / modification description Datum/date Name

A Raymond GmbH & Co. KG
 Teichstrasse 57
 Germany - 79511 Loerrach
 Phone +49 (0) 7621 174-0
 Fax +49 (0) 7621 174-225

Bei Verstaendnisproblemen beantragen Sie bitte beim Absender die deutsche Fassung vor jeder Anwendung.
"CONDITIONS OF USE"
 This drawing and all information (the "Drawing") disclosed are the exclusive property of A.Raymond. By using this Drawing the Addressee acknowledges and accepts that this Drawing (1) is covered by A.Raymond' intellectual property rights or know-how and (2) is provided under the following conditions who represent a Deposit Agreement. This Drawing is for Addressee' internal use only limited to its estimation. Without prior written consent of A.Raymond, no permission or rights for any purpose, is hereby granted, such as, without any limitation, (1) the copy, in part or entirely, (2) and/or the presentation, in part or entirely, to any other third party outside the Addressee' company or in the company but with no interest (3) and/or the distribution of the Drawing, in part or entirely, in any medium (4) and/or the creation of any derivative work. In case of breach of these conditions, Addressee shall indemnify A.Raymond from and against all damages (compensatory or consequential), costs, expenses and charges, caused or arising out of or attributable to its willful misconduct, fraud, negligence, infringement of A.Raymond' intellectual property rights. If the Addressee does not accept these conditions, please notify A.Raymond' sender immediately.

Schutzrechte/ patent rights	vorbehalten / all rights reserved		Rasch Code/ classification	EAAA-
Ersatz fuer/ substitutue for	011876_C_01/Aa/16.10.2008	Entw.Ref./ dev.ref.	Projekt-Nr./ project no.	

Masstab/ scale	Format	Allgemeintoleranz/ general tolerance	Datum/ date	04.08.2010
5:1	A3	±0.25	Erstellt von/ prepared by	Ruzicka

Projektion / projection	ALL DIMENSIONS ARE IN MILLIMETERS	Freigegeben/ approved	20100806115447		
Bleedicke/ mat. thickness DIN EN 10140	0.30	Volumen/ volume (mm³)	18.9	Gewicht/ weight (g)	0.2

Ab

Oberfl. / finish	phosphatiert / impraegniert phosphated / oiled	Oberfl. Code/ finish code	5100
---------------------	---------------------------------------------------	------------------------------	------

Werkstoffbehandl./ material treatment	zwischenstufenverguetet / austempered 435 ... 535 HV 3		
------------------------------------------	-----------------------------------------------------------	--	--

Werkstoff/ material	C67S DIN EN 10132-4	Mat. code	1000
------------------------	---------------------	-----------	------

Benennung/ title	Federmutter fuer Bolzen Ø 2 spring nut for bolt Ø 2		
---------------------	--------------------------------------------------------------	--	--

Teil-Nr. / part no.	011876-0-03	Drawing type	Customer
------------------------	-------------	--------------	----------

Kundenteile-Nr. / customer part no.	-	Blatt / sheet	1 / 1
CAD system & version	ProE WF3	Dateiname / filename	011876-0C00