

Stanzgrat / stamping burr

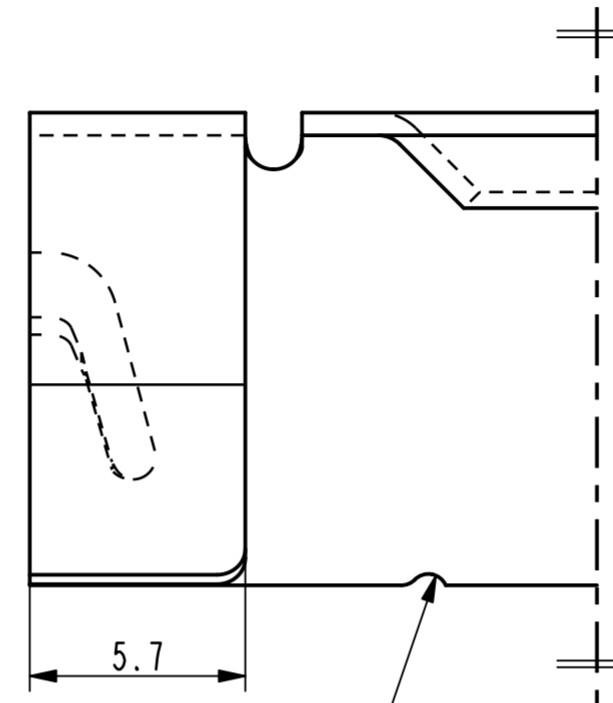

Ausklüfung zulässig / cutout permissible

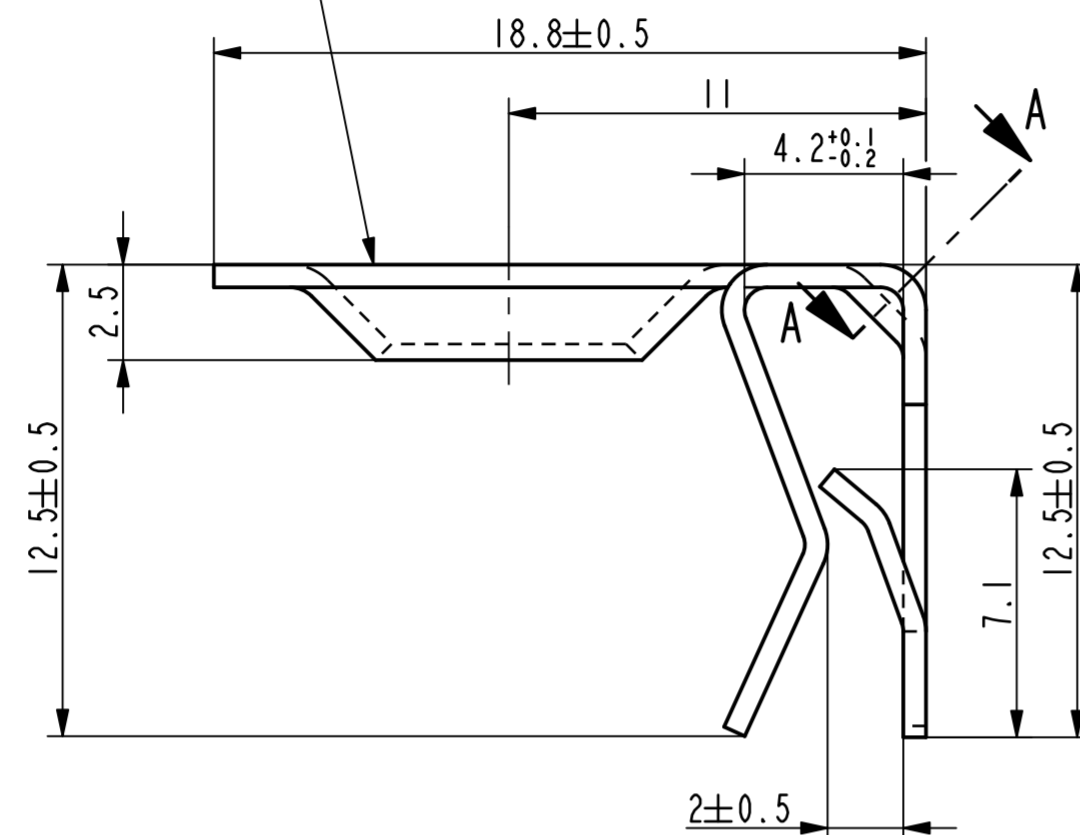
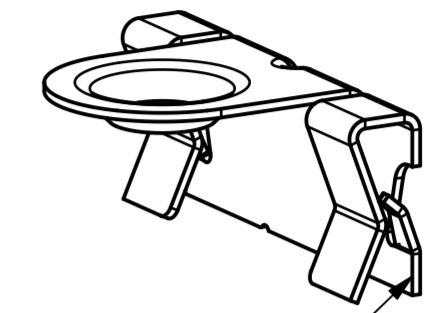
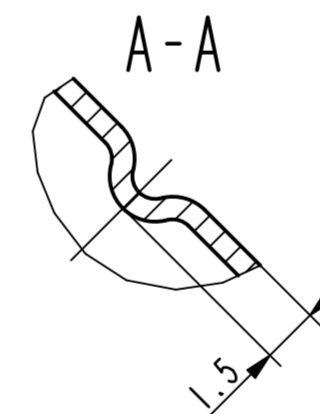
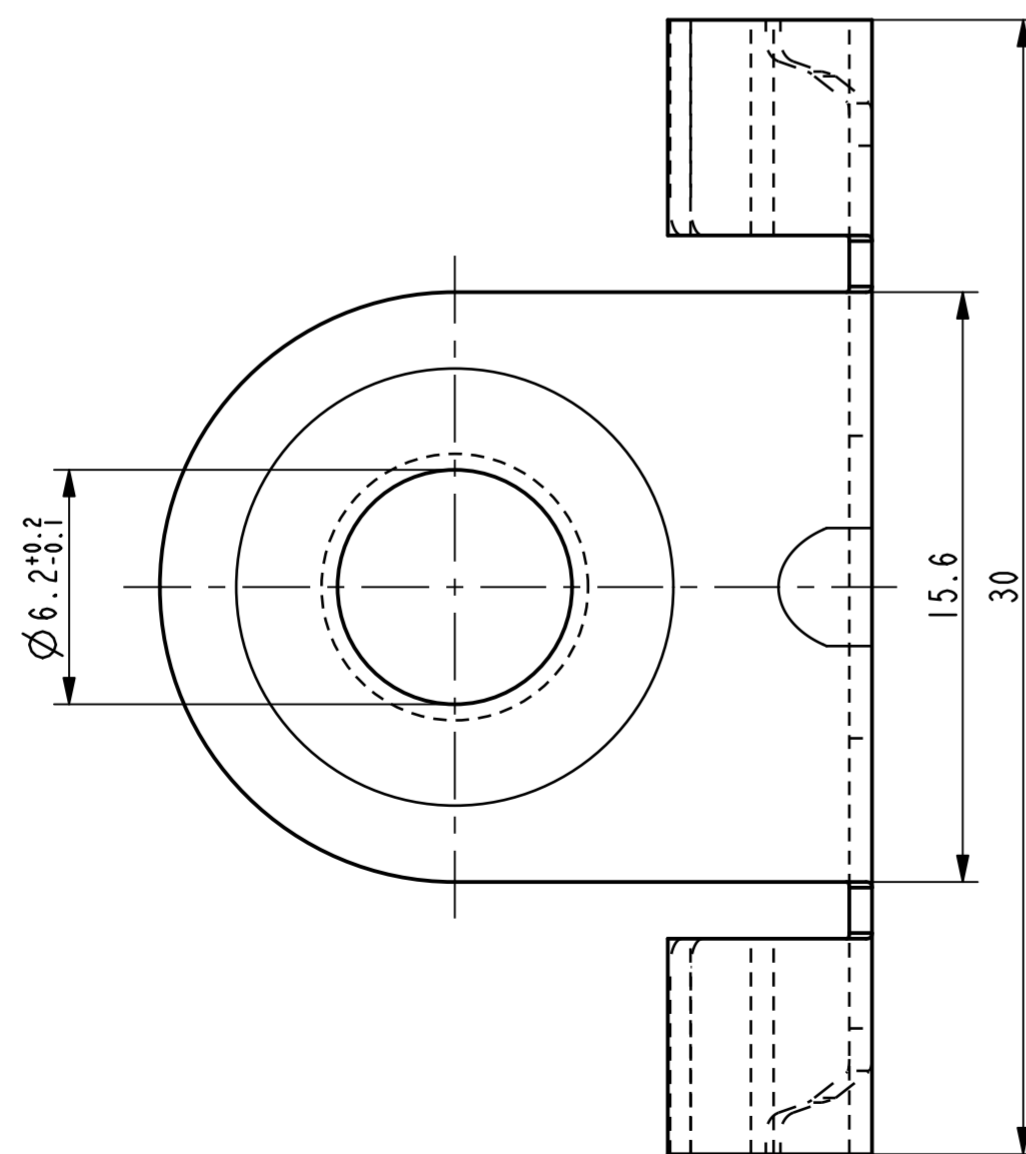

fuer Befestigungsdicke / for fastening thickness 3.5 ± 0.2

Isometrische Ansicht / isometric view 2:1

Vor Auslegung einer automatisierten Verarbeitung des Teils sollte Rücksprache mit Fa. ARAYMOND gehalten werden.
Fully automatic processing of the part requires prior consultation with ARAYMOND.

-	-	-	-	-
-	-	-	-	-
-	-	-	-	-
-	-	-	-	-
-	-	-	-	-
-	-	-	-	-
-	-	-	-	-
-	-	-	-	-
-	-	-	-	-
-	-	-	-	-
-	-	-	-	-
-	-	-	-	-
-	-	-	-	-
-	-	-	-	-
-	-	-	-	-
-	-	-	-	-
-	-	-	-	-

Aa	-	Oberflächenvariante entfernt (3000)	05.03.12	mj
----	---	-------------------------------------	----------	----

Rev.	Anzahl/quantity	Änderungsbeschreibung / modification description	Datum/date	Name
		ARAYMOND A RAYMOND GmbH & Co.KG		Teichstrasse 57 Germany - 79511 Loerrach Phone +49 (0) 7621 174-0 Fax +49 (0) 7621 174-225

Bei Verständnisproblemen beantragen Sie bitte beim Absender die deutsche Fassung vor jeder Anwendung.
"CONDITIONS OF USE"
This drawing and all information (the "Drawing") disclosed are the exclusive property of ARAYMOND. By using this Drawing the Addressee acknowledges and accepts that this Drawing (1) is covered by ARAYMOND's intellectual property rights or know-how and (2) is provided under the following conditions which represent a Deposit Agreement. This Drawing is for Addressee's internal use only limited to its estimation. Without prior written consent of ARAYMOND, no permission or rights for any purpose, is hereby granted, such as, without any limitation, (1) the copy, in part or entirely, (2) and/or the presentation, in part or entirely, to any other third party outside the Addressee's company or in the company but with no interest (3) and/or the distribution of the Drawing, in part or entirely, in any medium (4) and/or the creation of any derivative work. In case of breach of these conditions, Addressee shall indemnify ARAYMOND from and against all damages (compensatory or consequential), costs, expenses and charges, caused or arising out of or attributable to its willful misconduct, fraud, negligence, infringement of ARAYMOND's intellectual property rights. If the Addressee does not accept these conditions, please notify ARAYMOND's sender immediately.

Intellectual property rights	vorbehalten / all rights reserved		Classification code	YHB--
Ersatz fuer / substitute for	020305.c.01/A/30.06.2005	Entw./Ref./ dev.ref.	Projekt-Nr./ project no.	32281
Masstab / scale	5:1	Format	A2	Datum/ date
Projektion / projection		Allgemeintoleranz / general tolerance	±0.3 / ±5°	Erstellt von / prepared by
Blechkörte / sheet thickness	0.60	DIN EN 10140	Freigegeben / approved	20120305120056
		Volumen / volume (mm³)	467.9	Gewicht / weight (g)
				3.7

Oberfl. / finish	verzinkt / passiviert farblos zinc plated / passivated colourless	Oberfl. Code / finish code	3250
Werkstoffbehandl. / material treatment	zwischenstufenverguehtet / austempered 435 ... 535 HV 5		
Werkstoff / material	C67S DIN EN 10132-4	Mat. code	1000

Bezeichnung / title
Klammer
clip

Teil-Nr. / part no.	020305-0-02	Drawing type	C:Customer
Kundenteile-Nr. / customer part no.	-	Blatt / sheet	1 / 1
CAD system & version		ProE WF4	
Dateiname / filename		020305-0C00	

-	-	-
Teil-Nr. / part no.	Oberfläche / Farbe / finish / colour	Oberfl. Code / finish code
Ausführung / Execution		